

# FASCO

SECURITY PRODUCTS  
MPLS, MN

**GUN & PISTOL LOCKERS  
EVIDENCE LOCKERS  
PASS THRU DEVICES  
PERSONNEL LOCKERS**



**Fasco Inc**

14522 Naples St  
Ham Lake, MN 55304  
763-434-9841  
763-208-0979 fax

# FL 708-6 6 COMP PISTOL LOCKER FOR LAW ENFORCEMENT



**DESCRIPTION: 6 COMPARTMENT TIP OUT PISTOL LOCKER**

The FL series lockers are for high security pistol storage, primarily by law enforcement & military. They are often used in police stations, jails, courtrooms, sallyports, hospitals, etc

Body: formed 10 ga steel body, 35" wide x 29 1/2" high x 6" deep

Doors: 15 1/2"x 8 1/2"high, 10 ga steel door, lined w/ 1/8" thick felt

Hinge: 16 ga steel continuous piano hinge

Locks: Individually keyed & master keyed pin tumbler snap lock

2 keys per compartment, 2 master keys per locker

Mounting Frame: 2x2x1/8" steel angle frame, welded to body exterior. All joints welded & ground smooth

Finish: Chemically degreased & powder coat finish

**Specify surface mount or recessed mount, or semi recess**

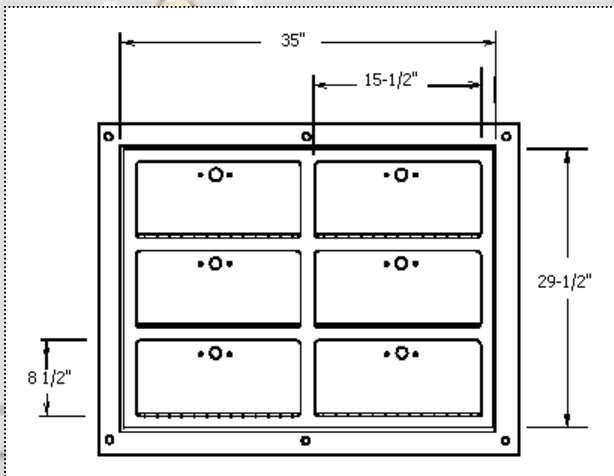

MODEL	# comps	SIZE	WT
FL-708-3	3	17 1/2 x 29 1/2	90#
FL-708-4	4	35 x 20	120#
FL-708-6	6	35 x 29 1/2	150#
FL-708-9	9	52 1/2 x 29 1/2	210#



## Fasco Inc

14522 Naples St  
Ham Lake, MN 55304  
763-434-9841  
763-208-0979 fax

# FL 708- -WP OUT DOOR MOUNT LAW ENFORCEMENT PISTOL LOCKER

DESCRIPTION: WP- Weather proof, or Exterior mount Gun Cabinets

The PL series lockers are also available with an exterior mounting option.

Material: 10 ga galvanized steel or #304 stainless steel

Doors: 10 ga doors w/ neoprene gasket & 1/8" thick neoprene compartment liner

Hinge: 16 ga stainless steel continuous piano hinge

Locks: Individually keyed & master keyed pin tumbler snap lock, (lock covers optional)

Mounting Frame: surface, recessed or semi recessed, or pedestal mounted  
All joints welded & ground smooth

Finish: #4 finish on stainless steel or powder coat on galvanized steel



FL-708-9/3. Also available in 6/3 & 12/3



Available in 3,4,6,9,10 & 12 compartments

## Fasco Inc

**14522 Naples St  
Ham Lake, MN 55304  
763-434-9841  
763-208-0979 fax**

# FC-700 PISTOL CABINETS



FC-700-6 GUN CABINET

The FC-700 Pistol cabinet is a high security cabinet for individual security of police & security officer weapons.

Made of heavy duty 10 ga steel welded steel construction. Each door is connected with a 16 ga piano hinge, & is secured with a groove key operated snap lock. It is designed with large 10"x10"x8"high compartments to accommodate the larger hand guns used by today's officers.

Locks are individually keyed pin tumbler snap bolt locks, & are master keyed. Doors are recessed into the body for extra security. Each compartment has a felt lined bottom & the complete unit is finished with a powder coat finish.

Cabinets can be surface mounted or recessed into the wall. Specify upon ordering.

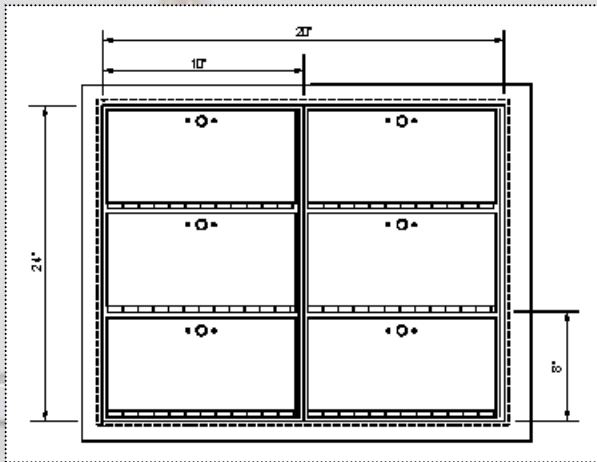

MODEL	# comps	SIZE	WT
FC-700-3	3	10 x 24x10	90#
FC-700-4	4	20 x 16x10	120#
FC-700-6	6	20 x 24x10	150#
FC-700-9	9	60 x 24x10	210#

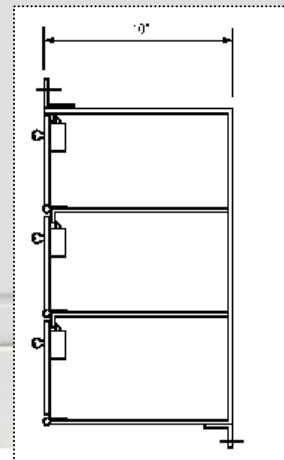

## Fasco Inc

14522 Naples St  
Ham Lake, MN 55304  
763-434-9841  
763-208-0979 fax

# FL 714-6

# 6 COMP PISTOL LOCKER MEDIUM DUTY



DESCRIPTION: 6 COMPARTMENT  
TIP OUT PISTOL LOCKER- Medium

This medium duty pistol locker is designed to offer a high level of security, with a lower price designed to fit your budget.

The body & compartments are built with 14 ga steel, piano hinge w/ non removable hinge & grooved key cam lock

Compartment size is the same 8 1/2"x15 1/2" as the higher level security models to hold the large hand guns, & felt lined to protect the guns finish. The doors are also recessed into the reinforced frame for resistance to prying.

After fabrication, the entire unit is degreased & coated with a powder coat finish

Specify recessed or surface mount when ordering. Units can be ganged together to form larger capacity units.

MODEL	# comps	SIZE	WT
FL-714-3	3	17 1/2 x 29 1/2	68#
FL-714-4	4	35 x 20	80#
FL-714-6	6	35 x 29 1/2	100#
FL-714-9	9	52 1/2 x 29 1/2	145#

## Fasco Inc

14522 Naples St  
Ham Lake, MN 55304  
763-434-9841  
763-208-0979 fax

# FLC-707-4 4 COMP PISTOL LOCKER



**FLC-707-4 Table Mount**



**FLC-707-1 Table Mount**



**FLC-707-1W Wall Mount**

## Fasco Inc

14522 Naples St  
Ham Lake, MN 55304  
763-434-9841  
763-208-0979 fax

The FLC-707-4 & FLC-707-4W Pistol Locker is our lightest duty locker. Its purpose is for controlling gun access in an area where protection from the public is not a major requirement.

16 ga formed steel body & doors & solid welded construction. Like the heavier models, these doors are recessed into the frame for pry resistance, & each compartment bottom is felt lined for the contents protection.

Each 4 compartment cabinet has mounting holes on all sides for ganging them together to form larger units.

Locks are individually keyed & master keyed cam locks

Finish painted w/ light tan powder coat finish paint



**FLC-707-4W Wall Mount**

# FLCR-748-3 RIFLE CABINET

DESCRIPTION: RIFLE/ LONG GUN LOCKER

The FLCR-748-3 Rifle locker is similar in design to the FLC style pistol lockers with tall compartments for safely securing long guns & rifles

Material: 16 ga formed cold rolled steel

Doors: 7"x45"x3/4" deep 16 ga steel, channel formed with welded corners

Hinge: 16 ga steel continuous piano hinge

Locks: Individually keyed & master keyed pin tumbler cam locks

Assembly: All electric arc welded construction, No spot welding

Finish: Chemically degreased & powder coat, light tan finish. Bottom is lined with 1/8" thick felt material to protect guns finish

These rifle cabinets are designed to be bolted to the wall or floor & can be bolted together for multiple weapon storage. They can also be used with Fasco's High Capacity Storage System for securely storing an entire arsenal, & for mass protection of military weapons. Contact us for more details.



## Fasco Inc

**14522 Naples St  
Ham Lake, MN 55304  
763-434-9841  
763-208-0979 fax**

# FLGC-700 WEAPON STORAGE CABINET



**FLGC-777-12 WEAPON  
CABINET**



**DESCRIPTION:** Weapon Storage cabinet

The FLGC-700 gun cabinets are custom made gun cabinets specially designed for secure multi gun storage

**Body:** formed 16 ga steel body, all welded construction. Perforated back panel for adjustable rifle, pistol & ammo options

**Doors:** 16 ga steel formed doors with welded corners, solid or perforated

**Hinge:** Continuous piano hinges

**Locks:** Keyed turn handle lock w/ 3 point latch

**Accessories:** Adjustable barrel rests, pistol rack, ammo shelves

Carpet lined butt rest with dividers

**Finish:** Chemically degreased & powder coat finish

**Sizes:**

**Model 777-12:** 42"x77"x15" 12 Rifle capacity

**777-15:** 44"x77"x15", 15 Rifle capacity

**748-12:** 42"x48"x15" 12 Rifle capacity

**784-12:** 42"x84"x15" 12-24 Rifle capacity

## Fasco Security Products

**14522 Naples St  
Ham Lake, MN 55304  
763-434-9841  
763-208-0979 fax**



# **EL-772 EVIDENCE LOCKER**

**+P for Pass Thru      +N for Non Pass Thru**

Fasco Security Products also offers a high security evidence locker for use in police stations & jails to securely pass various sized evidence from a non secured area to an evidence room. Each compartment has an individual front door, & all compartments are accessed from the secured side w/ large reinforced steel doors.

Individual compartment doors & frames are constructed of heavy 16 ga formed steel on 16 ga piano hinges & secured with keyless front entry latches, or master keyed snap locks.

The officer simply opens the compartment & puts in the evidence with the proper documentation, closes the door & operates the latching system. After the evidence is removed & processed, the controller releases the internal latch thus tagging it as an available compartment for use again.

Contact our sales office to discuss available sizes & to coordinate with various types of construction & for a full specification.



**INTERNAL VIEW-  
LATCH RELEASE**



**ELP-772-0110  
w/ ELRI-004**



**ELP-772-0107**

## **Fasco Inc**

**14522 Naples St  
Ham Lake, MN 55304  
763-434-9841  
763-208-0979 fax**

# EVIDENCE LOCKER ELEVATIONS

## STANDARD FRONT ELEVATIONS

Add prefix -P for pass thru -N for Non pass thru

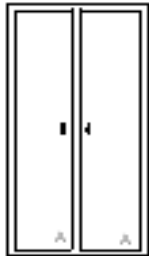

0102

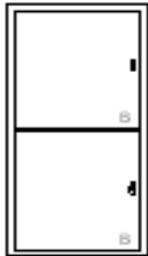

0102A

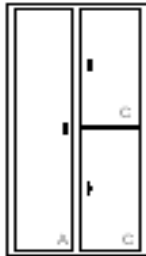

0103

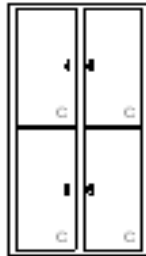

0104

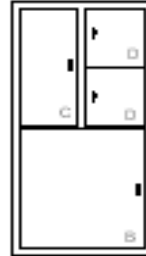

0104A

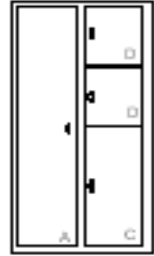

0104B

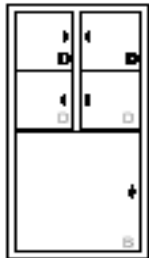

0105

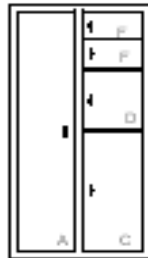

0105A

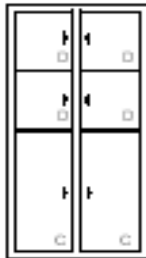

0106



0107



0108

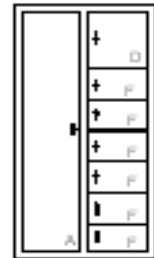

0108A



0108B



0110



0115

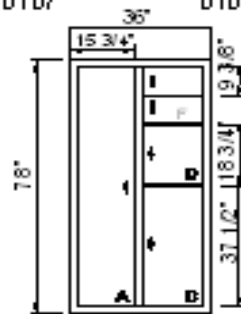

NO MINIAL SIZES



ELR-F004

# Fasco Inc

14522 Naples St  
Ham Lake, MN 55304  
763-434-9841  
763-208-0979 fax

Web site: [www.fascosecurityproducts.com](http://www.fascosecurityproducts.com)

# ELR-772 REFRIGERATED EVIDENCE LOCKER

ELR-772 Refrigerated Evidence Lockers

Stainless steel interior & exterior

Cooling range, 38deg F to 30 deg

Magnetic door seals

Power indicator light

Keyed lock, or keyless locking system

115V power cooling system

Stainless steel exterior finish

Various sized interior compartments

36"x78" os cabinet dimensions

Front load or pass thru option



R-0004

R-0006

R-0008

R-0012

R-0009

R-0018

R-0024

## Fasco Inc

14522 Naples St  
Ham Lake, MN 55304  
763-434-9841  
763-208-0979 fax

# FPPL-POLICE PERSONNEL LOCKER

The FPPL, Police Personnel Locker was designed to specifically meet the storage needs of the law enforcement officer. The features and options available make this product a versatile storage solution. All welded construction and heavy gauge materials provide both durability and life cycle cost advantages.

## Standard Features

Welded construction

Available in 18, 24, 30, or 36 inch widths

Upper unit available in heights of 61 or 73 inches

All 16 gauge body parts

Three point, three sided Cremone style turn handle latching

14 gauge louvered door

Full 4-sided continuous door strike

Full width top shelf

Interior lockable security compartment

Extra 12 inch wide shelf below security compartment

Pegboard back panel in door

Separate uniform compartment with clothes rod

Removable boot tray

17 inch tall full extension self-latching drawer base with 250 lb. rated ball bearing drawer glides

Integral 1 1/4" thick maple butcher block bench

T.G.I.C. Pure polyester powder coat finish

4 gang electrical box knock out or plug & play electrical strip

Limited Lifetime Warranty

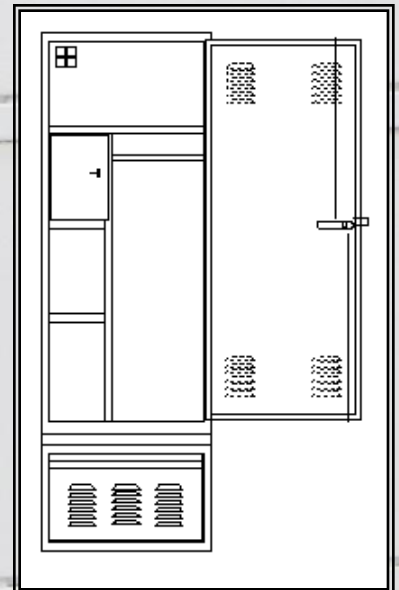

# Fasco Inc

**14522 Naples St  
Ham Lake, MN 55304  
763-434-9841  
763-208-0979 fax**

# FPP-700 PACKAGE PASS THRU

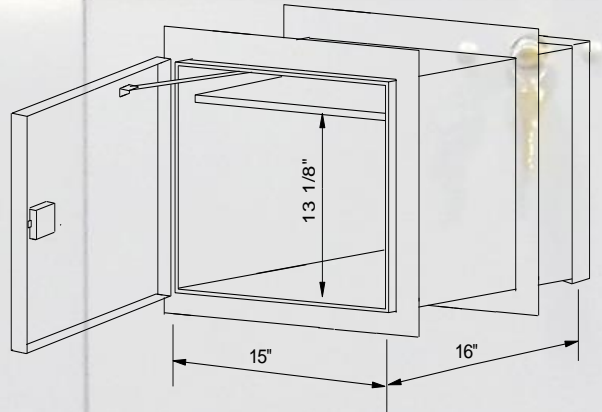
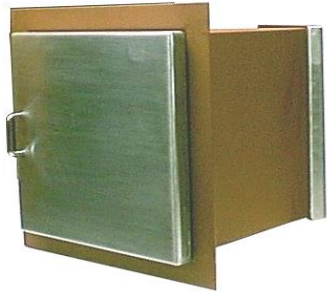

Shown w/ stainless steel door option

## DESCRIPTION: THRU WALL PACKAGE PASS

(Also known as Package Receiver)

- DOOR: 10 ga formed steel doors, each side
  - BODY: 10 ga steel top, bottom & sides
  - FRAME: 2"x10 ga steel frame, 4 sides, cut & notched at each corner to create a smooth square corner, field weld after installation
  - HINGE: 16 ga piano hinge, concealed under door
  - LATCH: Interlocking control allows one door to operate at a time, w/ closer on front door
  - All welded & ground construction
  - FINISH: chemically degreased, w/ 1 coat rust inhibitive primer  
#4 finish on stainless steel doors
- OPTIONS: 12 ga Stainless steel doors  
Bullet resistant construction Class 1 & class 3  
Vision panel in door

# Fasco Inc

14522 Naples St  
Ham Lake, MN 55304  
763-434-9841  
763-208-0979 fax

# PH-700 PASS HOPPER

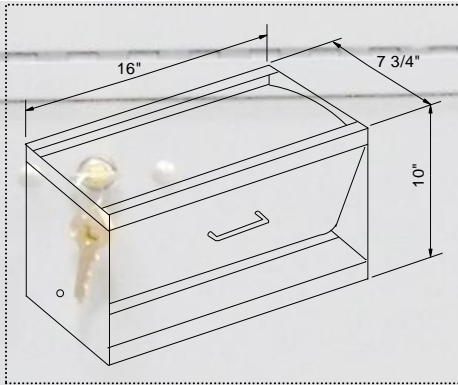

# PD-700 PASSDRAWER



## DESCRIPTION: PASS HOPPER PH-700

**FRAME:** Formed stainless steel construction, assembled to fit a standard block size width. 16"w x 10"h x 7 3/4"d

**HOPPER:** Rolled stainless steel hopper with pull handle & 1/2" dia pivot pins on oilite bushings.

**LATCH:** slide bolt latch only on secured side of hopper

**FINISH:** #4 finish on exposed stainless steel

**OPTIONS:** Level I or Level III front available

PH-716 16"w x 16"h x 12"d

## DESCRIPTION: PASS DRAWER PD-700 also known as Transaction drawer

**Body:** 10 ga formed steel body w/ top hatch on control room side overall dimensions, 22"w x 13"h x 24"d

**Drawer:** 10 ga steel w/ heavy duty zinc plated drawer slides mounted for operation from control room side only

**Drawer front:** 12 ga stainless steel, #4 finish

**Frame:** 12 ga formed stainless steel, #4 finish

**Options:** All stainless steel construction

Custom sizes, Class 1 & class 3 bullet resistant

**Fasco Inc**

**14522 Naples St  
Ham Lake, MN 55304  
763-434-9841  
763-208-0979 fax**

**Fasco Security Products** is a manufacturer of high quality gun cabinets for use by military, CIA, FBI, US Customs, Correctional officers & any type of law enforcement. Each product is designed specifically for the law enforcement environment. Our engineers have over 30 years of experience in designing high security products for jails & prisons, law enforcement & military applications.

We can also custom manufacture any type of gun cabinet you desire if our standard products don't fit your requirements. Call or email us at [sales@fascosecurityproducts.com](mailto:sales@fascosecurityproducts.com)

Also contact us for information regarding our GSA Federal Supply Schedule Contract.

**Fasco Inc**  
**14522 Naples St**  
**Ham Lake MN 55304**  
**763-434-9841**  
**763-208-0979 Fax**  
**Sales@fascosecurityproducts.com**



**Fasco Inc**

**14522 Naples St**  
**Ham Lake, MN 55304**  
**763-434-9841**  
**763-208-0979 fax**