



Gliding Basement Window

## Northview Gliding Basement Window

- Energy Efficient, Maintenance Free PVC Frame & Sash
- Fusion Welded Corners
- Available as Standard or Cavity Mount
- Single Slider Design for Stronger, Tighter Window
- Sash Rollers for Ease of Operation
- Operating Sash Easily Removes for Cleaning

## Northview Hinged Basement Window

- Energy Efficient Maintenance Free PVC Sash & Frame
- Fusion Welded Frame & Sash Corners
- Available as Standard or Cavity Mount
- Concealed Adjustable Hinge System and Lever Handle Sash Latches
- Full Screen
- Available as Hopper, Awning or Casement



Hinged Basement Window

### CONSTRUCTION

Extra thick PVC frame and sash. Fusion welded corners prevent leaking. "integral installation fin on frame. Available in standard or cavity mount design. Multiple contact weather strip protects against air and water infiltration. Energy efficient PVC and "double pane insulating glass keeps interior surfaces warmer for additional comfort. Low-e glass optional for improved thermal performance.

### SIZES

Numerous standard sizes available. Designed to fit 2, 2-1/2 and 3 block openings. Many gliding and hinged sizes are interchangeable for design flexibility. Custom sizes available to allow upgrade of older homes.

### OPERATION

The Glider is single-slider style for a stronger, more energy efficient window. Operating sash features rollers for ease of operation. A hook style die cast metal sash lock and screen is included.

The Hinged window is available as Awning, Hopper or Casement style and features an adjustable friction fit hinge system and lever handle sash latches. All units feature a full screen.

### WARRANTY

Limited Lifetime Warranty on frame and parts. Ten year glass warranty. See warranty for further details and information.

## Basement Window Sizes and Elevations

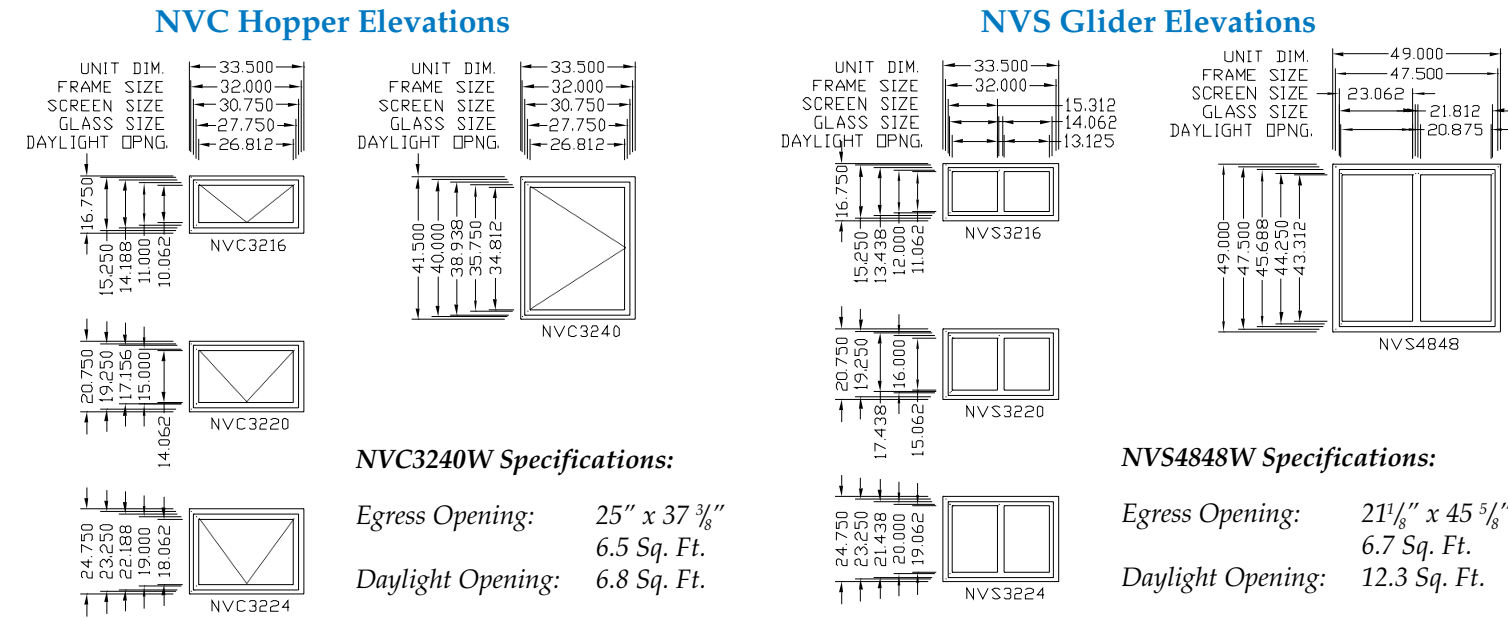

Northview Windows offer maximum value!  
All fusion-welded frames and sash combined with aesthetically pleasing design and function provide the strength, durability and comfort you want and deserve.

Our numerous features such as integral buck and window combination, tie-slots, factory applied well mounting bolts, solid bracing and product protection save job-site costs and give you a competitive advantage.

Our wide range of products, sizes, features and flexibility make Northview the most versatile below-grade window product in the industry.



Where Innovation and Quality is standard with every product!



Northview Window & Door  
498 Maratech Avenue  
Marathon, WI 54448  
Phone: 1-877-689-4636  
715-443-2300  
Fax: 715-443-2250  
www.northviewwindows.net



Where Innovation and Quality is standard with every product

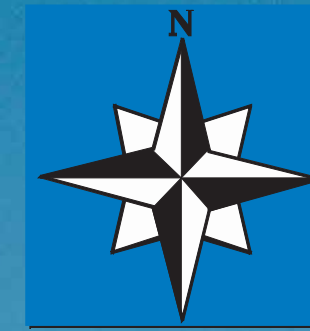

# NORTHVIEW WINDOWS

## Basement Window System Product Selection Guide





Perma-Buk Pro Glider Window

## “Perma-Buk Pro” Glider / Hopper Window

### Why it's Better...

- Extra Thick Welded PVC Frame & Sash
- Energy Efficient PVC Construction
- Double Slider with Rollers for easy operation
- Industry-first Design Eliminates Upside Down or Inside Out Pours
- 3/4" Insulated Glass for Energy Efficiency
- Supplied with Bracing and Protective Film for poured wall or block installations
- Limited Lifetime Warranty

### CONSTRUCTION

We use Extra Thick PVC materials on all our Perma-Buk Pro windows, and then fusion weld the frame and sash corners to assure years of trouble free performance. Our fully welded frames and sash assure that the weather will stay out and the corners will not “open up” over time as with mechanical fastened corners. Our windows are designed with 3/4" insulated glass\*, a sloped sill and fin-seal weather-stripping to provide an energy efficient combination. To make installation easier, our windows are fully assembled and braced to reduce your on-site labor costs. We even apply a protective film inside and out to prevent against frame damage during construction. Our new innovative Gliding window design eliminates the possibility of installation being upside down or backwards.

\*Optional Low-E glass is available for improved thermal performance



Perma-Buk Pro Hinged Window

### OPERATION

All our Perma-Buk Pro Gliders feature dual sash operation with two rollers on each sash for easy operation and maximum ventilation control. The sash features a cam style lock for a positive seal and maximum security. Our Perma-Buk Pro Hinged windows are available in Awning/Hopper or Casement style. They feature a friction fit hinge system and double lever handle sash locks. All units feature an aluminum-framed, fiberglass mesh screen.

### GLIDER SIZES

3216 (actual frame size 31-7/8" x 15-7/8")  
 3220 (actual frame size 31-7/8" x 19-7/8")  
 3224 (actual frame size 31-7/8" x 23-7/8")

### HINGED SIZES

3216 (actual frame size 31-7/8" x 15-7/8")  
 3220 (actual frame size 31-7/8" x 19-7/8")  
 3224 (actual frame size 31-7/8" x 23-7/8")  
 3240\* (actual frame size 32" x 40")

### WARRANTY

All Northview products feature a Limited Lifetime Warranty on frame and parts, Ten year against glass seal failure and 12 month glass stress crack Warranty from the original date of purchase.

\* NVPC3240W meets Egress requirements  
 Egress opening: 24-1/4" x 37-1/4" (6.27 sq. ft.) Daylight opening: 6.48 sq. ft



Perma-Buk III - 32x40 Hinged Egress Window

### CONSTRUCTION

Extra thick welded PVC frame and sash. Energy efficient PVC keeps interior surfaces warmer and reduces interior condensation. Window is an integral part of the Buk frame (no further window installation is necessary). Large exterior fins ensure the Perma-Buk will stay secure in the concrete. Sloped sill promotes water drainage. Glazed with " dual pane insulating glass. Units fully weather-stripped to protect against air and water infiltration. "Perma-Buk III" is fully braced and covered with protective film to prevent against frame distortion, damage and post construction clean-up.

### OPERATION

Available as Glider, Awning/Hopper or Casement style. Glider is double-slider style and features sash rollers for ease of operation and cam style sash lock for positive seal and security. Hinged windows feature friction fit hinge system and lever handle sash latches. All units feature an aluminum-framed, fiberglass mesh full screen.



Perma-Vent Crawl Space Vent

### CONSTRUCTION

Extra thick welded PVC Frame and vent insert. Multiple wall widths for installation in poured and concrete block construction. Vent easily opens and closes from exterior providing ventilation in any season. Mesh screen protects against unwanted animals and debris.

## “Perma-Buk III” Installation System

### Why it's Better...

- Extra Thick Welded PVC Frame
- Fusion Welded Corners Prevents Leaking
- Compatible with all Types of Forms
- Window is an Integral Part of the Buk Frame. No Further Window Installation Required
- Available as Gliders or Hinged Windows
- Several Egress Sizes and Styles Available
- Available in Multiple Wall Thicknesses
- Factory Punched Tie Slots for Easy Installation
- Pre-Mounted Well Bolts Available
- Bracing Supplied – Ready for Installation
- Limited Lifetime Warranty

### SIZES

Available in numerous sizes and wall thicknesses to fit poured and block wall construction. Several egress sizes and window styles available.

### FEATURES & OPTIONS

Welded corners provide a quality finish and eliminate leaking. "Perma-Buk III" is compatible with wood, aluminum or steel forms. Frame design provides an attractive finished opening eliminating the need for additional trim. Factory punched tie slots 36" on center for easier installation into aluminum and steel forms. Pre-mounted well bolts and mounting plates available to simplify window well mounting. Accessory groove in frame allows use of various trim products. Optional Low-e glass for improved thermal performance.

### WARRANTY

All Northview products feature a Limited Lifetime Warranty on frame and parts. Ten year glass warranty. See actual warranty for further information.

## “Perma-Vent” (Crawl Space Vent)

- Extra Thick Welded PVC Frame
- Available in Multiple Wall Widths
- Easy operating vent
- Mesh screen protects against pests and debris

### SIZES

Overall "Perma-Buk" frame size is 19-3/9" wide x 11-1/8" high. Vent size is 16" x 8"



Perma-Buk III Hopper Hinged Window



Perma-Buk III Glider Window

### Perma-Buk III Hopper Elevations

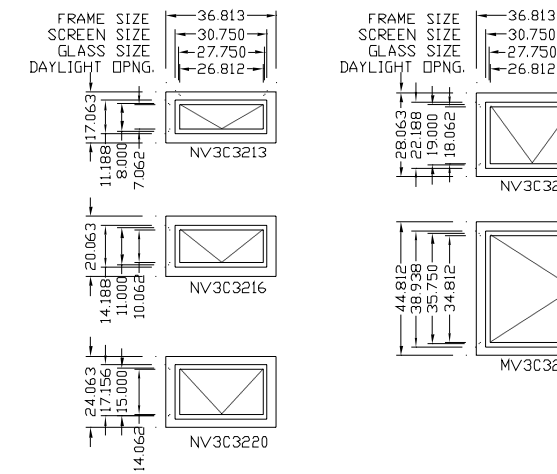

### Perma-Buk III Slider Elevations

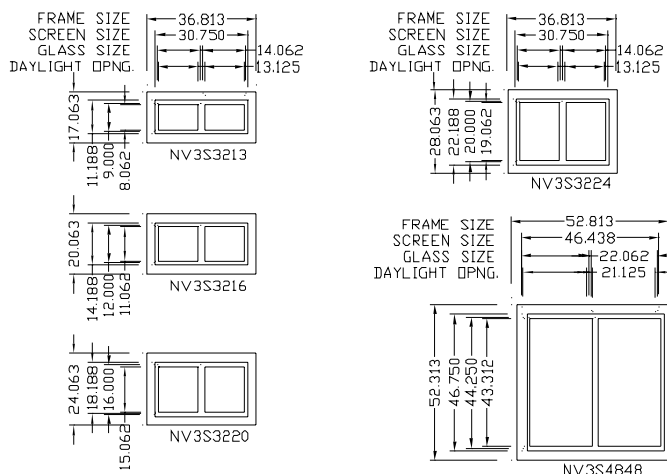

#### NV3C3240W Specifications:

Egress Opening: 25" x 37<sup>3</sup>/<sub>8</sub>"  
 6.5 Sq. Ft.  
 Daylight Opening: 6.8 Sq. Ft.

#### NV3S4848W Specifications:

Egress Opening: 21<sup>1</sup>/<sub>4</sub>" x 44<sup>7</sup>/<sub>8</sub>"  
 6.62 Sq. Ft.  
 Daylight Opening: 12.42 Sq. Ft.



Perma-Buk III Awning Hinged Window



pre-punched labor-saving wall tie slots & pre-mounted well bolts

NVB3213W, NVB3216W, NVB3220W, NVB3224W and NVB3240W are designed to be used with 36" on center ties.

Available in 7<sup>1</sup>/<sub>4</sub>", 7<sup>3</sup>/<sub>8</sub>" (nominal), 7<sup>7</sup>/<sub>8</sub>" (full), 9<sup>1</sup>/<sub>4</sub>", 9<sup>5</sup>/<sub>8</sub>" and 9<sup>7</sup>/<sub>8</sub>" widths. 2" adapter kits available for wider widths.

All sizes are available in multiple wall thicknesses: 7<sup>1</sup>/<sub>2</sub>", 7<sup>7</sup>/<sub>8</sub>", 9<sup>1</sup>/<sub>2</sub>" & 9<sup>7</sup>/<sub>8</sub>" or 11<sup>7</sup>/<sub>8</sub>".